

80A DIAPHRAGM VALVE

Advantages of 80A Diaphragm Valve

- Highly efficient and large capacity 3"(80A) blow tube applied valve.
- With internal impulse type diaphragm set employment, impact reduction and durability enhancement at opening and closing.
- Header Type released: easy installation, easy maintenance and excellent performance.



JISI 80A



JIHI 80A

■ PART DRAWING

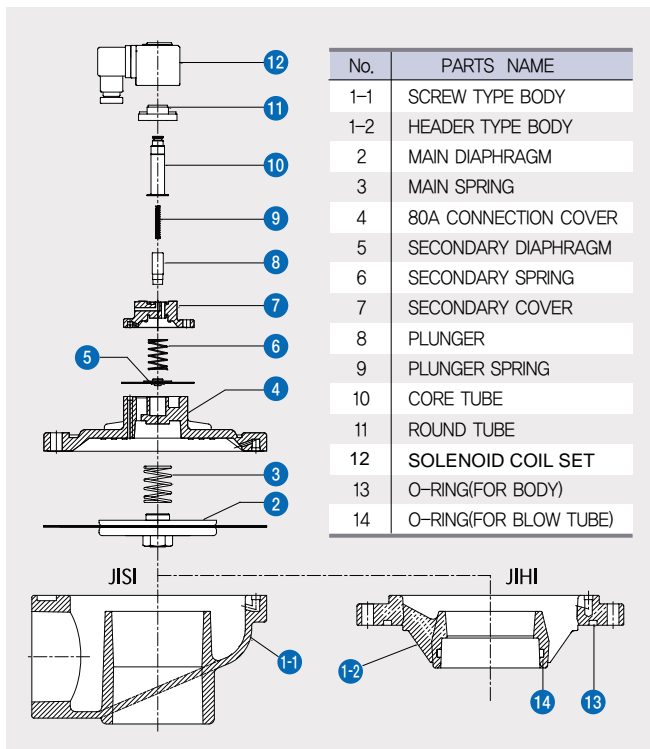

■ HEADER TYPE ASSEMBLY DRAWING

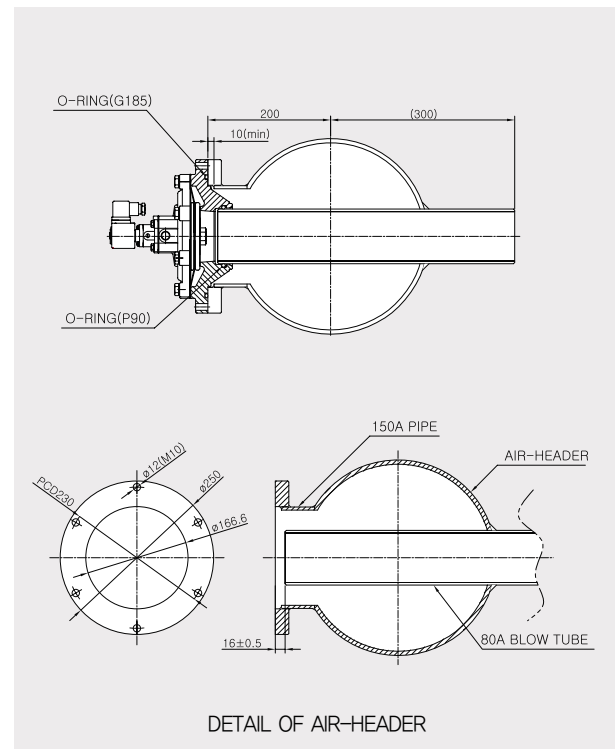

■ SPECIFICATION

MODEL	C.V FACTOR	Rate of discharge(ℓ/0.1sec.pulse)					Operating Pressure		Weight (kg)
		3Kg/cm ²	4Kg/cm ²	5Kg/cm ²	6Kg/cm ²	7Kg/cm ²	MIN	MAX	
JISI 80	230.3	303	378	453	528	603	0.5	8	4.36
JIHI 80									3.48
JISR 80									4.16
JIHR 80									3.28