

# Resistance Temperature Detectors

## Model. DS-3040 Series (Sheath Type)

# DAESHIN

### Sheath 측온저항체의 원리

측온 저항소자를 Stainless 강 극세관(Sheath)에 삽입한 후, 도선과 Sheath와의 절연을 위하여 무기절연물로 강고히 충전시킨 구조를 Sheath 측온 저항체라하며, 일반적인 측온 저항체에 비하여 절연성 및 내압성이 우수합니다.

Ceramic 소자를 MI Cable(MgO를 충전한Lead Wire)에 접속하여 하나의 조로된 Sheath 측온저항체로서 종래의 저항체에 비하여 응답속도가 대단히 빠르며 나쁜 조건하에서도 긴 수명을 유지하도록 되어 있습니다.

### Sheath 측온저항체의 특징

- ▶ 폭넓은 측정범위  
: 외경이 아주 가늘어 작은 측정물에도 간단히 삽입이 가능하며 -200°C~600°C까지의 폭넓은 범위에 사용이 가능합니다.
- ▶ 빠른 응답속도  
: 극세관형이므로 미세한 온도 변화에도 민감히 응답합니다.
- ▶ 굴절가공이 용이  
: Sheath 외경의2배 이상하여 굴곡이 많은 장소나 현장에서 간단히 취부할 수 있습니다.  
(단, 끝 단부 50mm를 제외함)
- ▶ 긴 수명  
: 종래의 측온저항체에 비교하여 씨즈 측온저항체의 도선과 저항소자는 화학적으로 안정된 산화마그네슘으로 절연시켜 기밀이 잘되고 충격 및 단선 등에 대하여 강하며 수명또한 깁니다.
- ▶ r기계적 강도, 내진성이 좋다  
: 진동이 있는 장소, 부식성 분위기의 풍의 조건에서도 사용이 가능합니다.
- ▶ 씨즈 외경 제조 가능크기  
: 씨즈 외경 Ø1.6~Ø12.75 까지 제작이 가능합니다.
- ▶ 길이가 긴 것도 제조 가능  
: 씨즈 외경에 따라 최장 50m까지 제작 가능합니다.
- ▶ 특수한 환경에서도 설치 가능  
: 씨즈 외경이 가늘고, 굴절가공이 쉬워 장소를 불문하고 피측정체의 흐름을 방해하지 않고도 취구가 가능합니다.  
씨즈 외경의 종류도 많아 한 개의 씨즈에 소자(6도선)형태도 제작이 가능합니다. 이와같이 M.i ResiTec은 여러 형태의 환경에서 폭넓게 사용할 수 있습니다.



Model. DS-3043W

### Sheath 측온저항의 표준기호

Nominal Resistance	Code	Nominal Resistance	Code
DIN Pt 100Ω at 0°C	PT100	1 (Single)	S
JIS Pt 100	JPT100	2 (Double)	D

Number of Leads	Code
2 Wires	W
3 Wires	X
4 Wires	Y

Pressure Gauge

Accessories

Thermometer

Thermocouple & R.T.D



Thermowell

# Resistance Temperature Detectors

## Model. DS-3040 Series (Sheath Type)

# DAESHIN

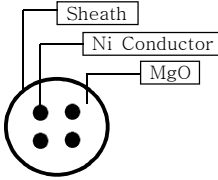
### Sheath Leads

	Sheath O.D (mm)	Conductor Dia (mm)	Lead Resistance ( $\Omega/m$ at 20°C)	Sheath Wall(mm)	Sheath Material	Max Length (m)
	3.2	0.45	0.627	0.48	316SS	150
	4.8	0.70	0.248	0.73	316SS	60
	6.4	0.93	0.15	1.02	316SS	30
	8.0	1.14	0.099	1.27	316SS	15
	4.8	0.38	0.8881	0.457	316SS	60
	6.4	0.48	0.55	0.63	316SS	30
	8.0	0.63	0.31	0.78	316SS	15

Pressure Gauge

Accessories

Thermometer

Thermocouple & R.T.D

Thermowell

### Response Time of Sheath Resistance Bulb

The "t" Constants (63.2%) when RESIMIC is immersed into 100°C (boiling water) from 0°C(ice bath)

- Ø3.2 less than 2 sec.
- Ø4.8 less than 4 sec
- Ø6.4 less than 6 sec.
- Ø8.0 less than 11 secretary.

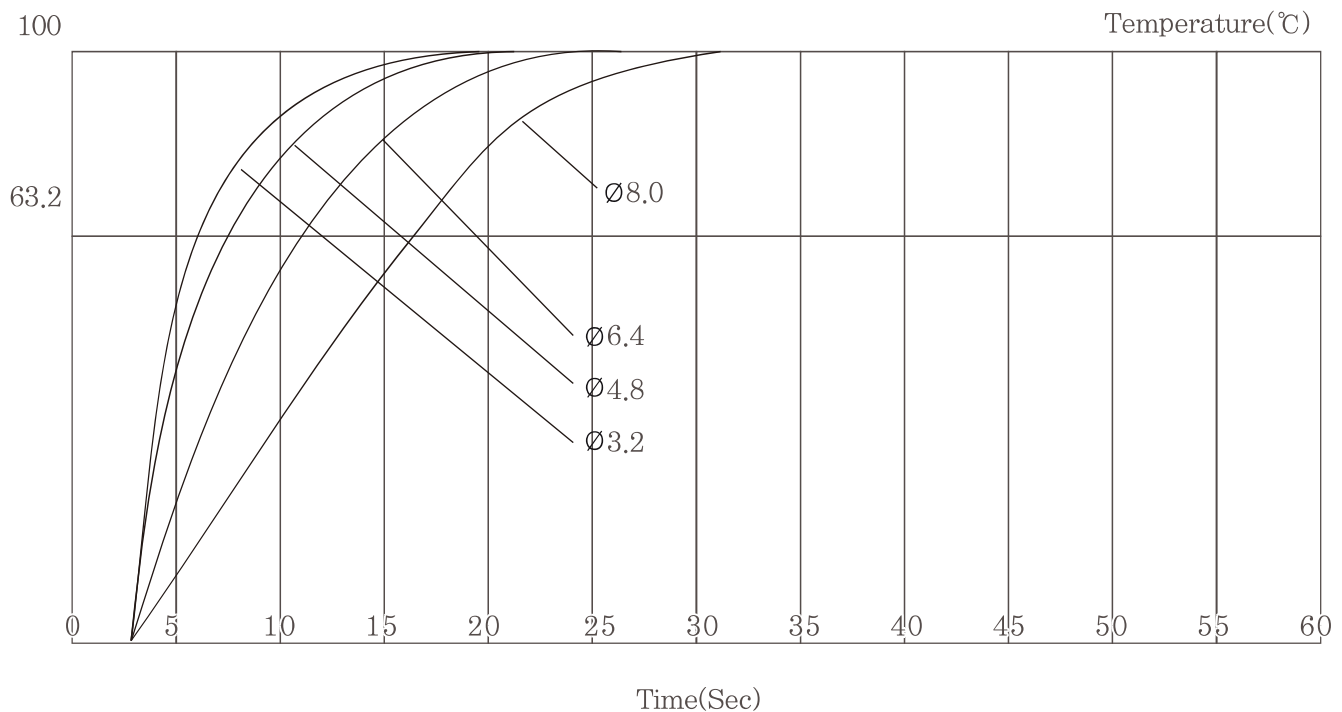

# Resistance Temperature Detectors

## Model. DS-3040S Series

# DAESHIN

### General Purpose Head Type

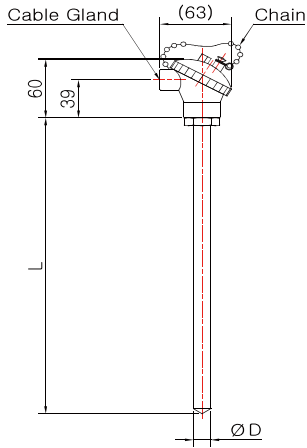

**Model No. DS-3041S**  
(Sheath)

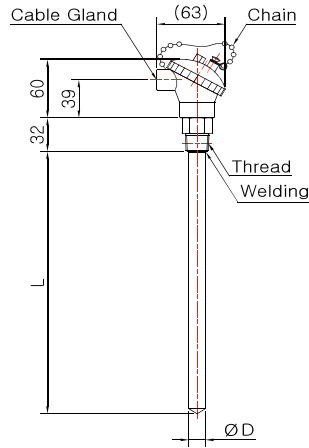

**Model No. DS-3041S-2**  
(Sheath)

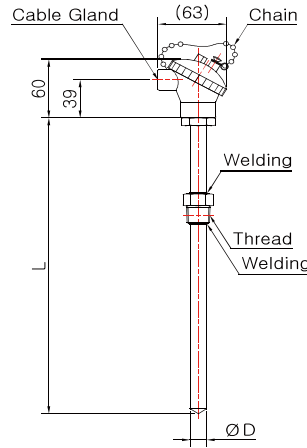

**Model No. DS-3042S-1**  
(Sheath)

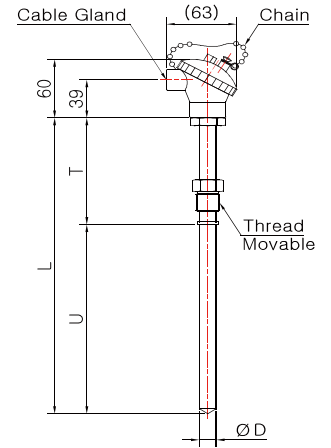

**Model No. DS-3042S-2**  
(Sheath)

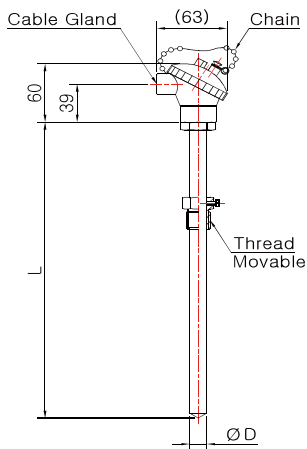

**Model No. DS-3042S-3**  
(Sheath)

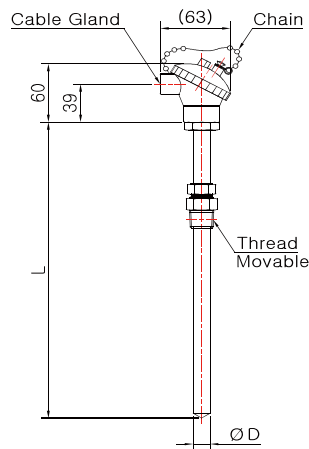

**Model No. DS-3042S-4**  
(Sheath)

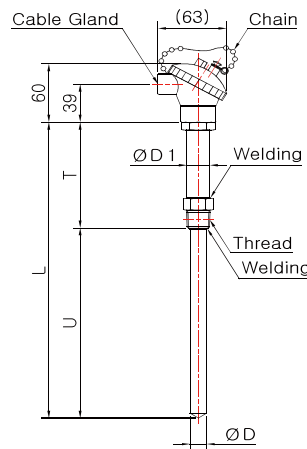

**Model No. DS-3043S**  
(Sheath)

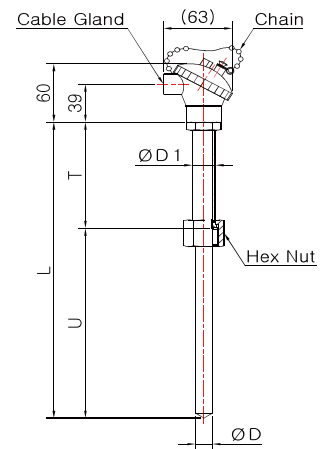

**Model No. DS-3043S-1**  
(Sheath)

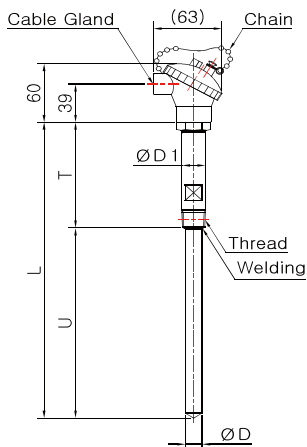

**Model No. DS-3044S-1**  
(Sheath)

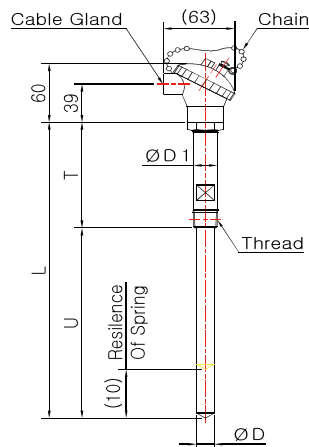

**Model No. DS-3044S-1-1**  
(Sheath Spring Load)

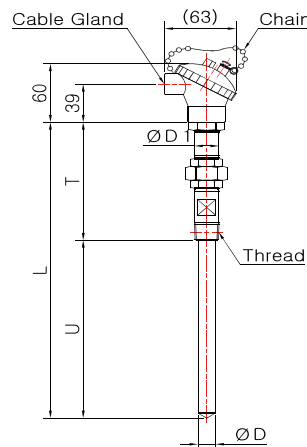

**Model No. DS-3044S-2**  
(Sheath)

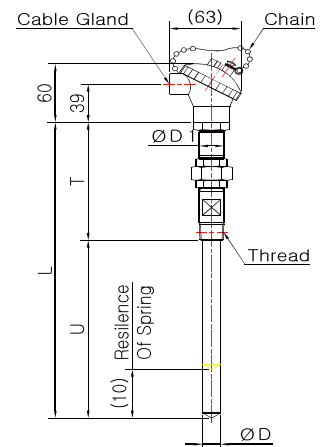

**Model No. DS-3044S-2-1**  
(Sheath Spring Load)

Pressure Gauge

Accessories

Thermometer

Thermocouple & R.T.D

Thermowell

# Resistance Temperature Detectors

## Model. DS-3040S Series

# DAESHIN

### General Purpose Head Type

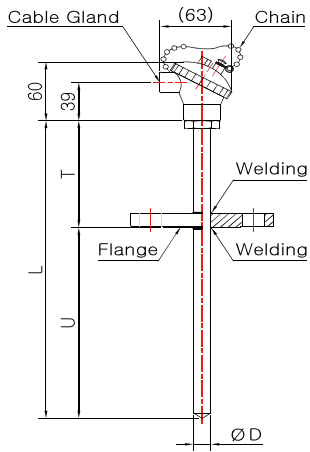

**Model No. DS-3045S**  
(Sheath)

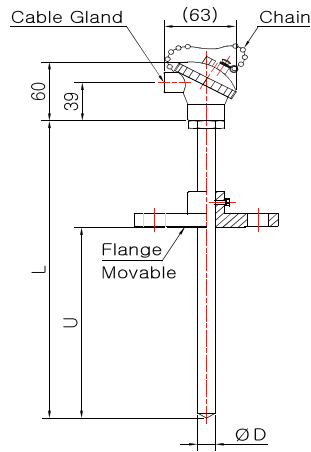

**Model No. DS-3045S-1**  
(Sheath)

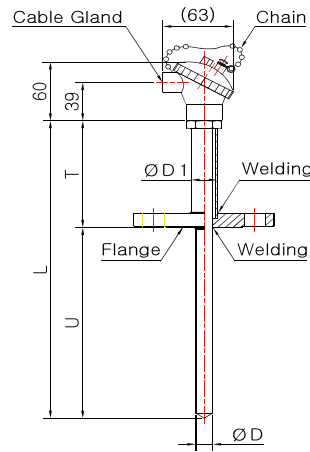

**Model No. DS-3046S-1**  
(Sheath)

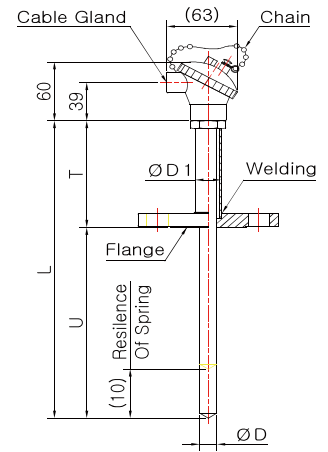

**Model No. DS-3046S-1-1**  
(Sheath Spring Load)

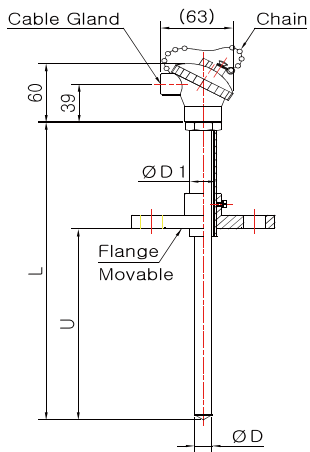

**Model No. DS-3046S-2**  
(Sheath)

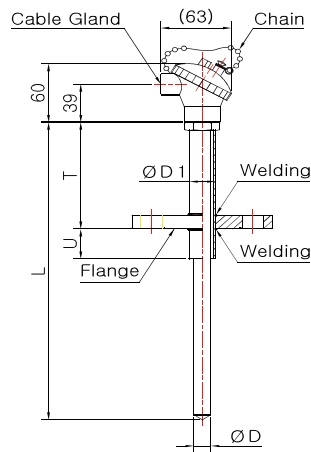

**Model No. DS-3046S-3**  
(Sheath)

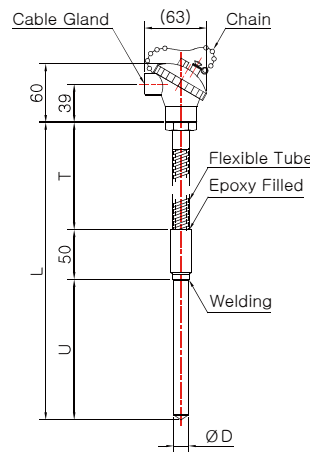

**Model No. DS-3049S**  
(Sheath)

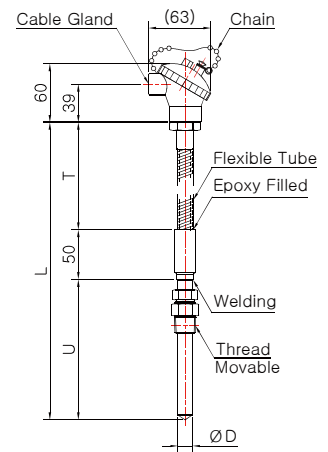

**Model No. DS-3049S-1**  
(Sheath)

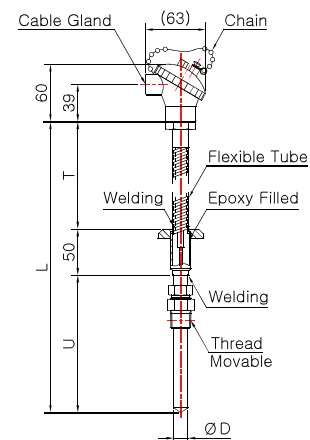

**Model No. DS-3049S-3**  
(Sheath)

Pressure Gauge

Accessories

Thermometer

Thermocouple & R.T.D

Thermowell

# Resistance Temperature Detectors

## Model. DS-3040W Series

# DAESHIN

### Weather Proof Head Type

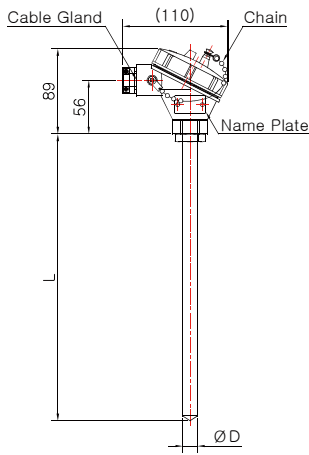

**Model No. DS-3041W**  
(Sheath)

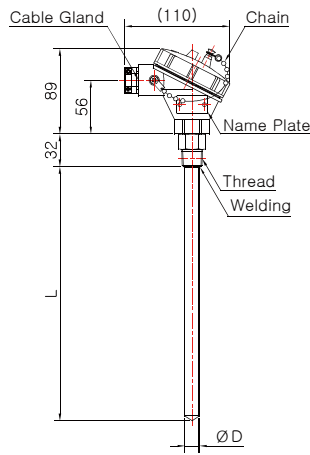

**Model No. DS-3041W-2**  
(Sheath)

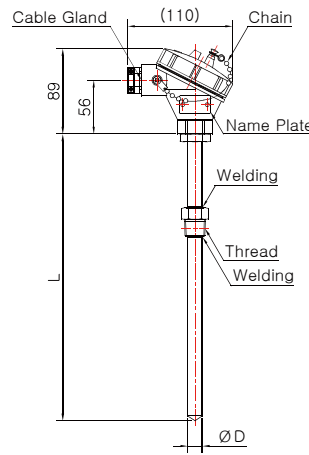

**Model No. DS-3042W-1**  
(Sheath)

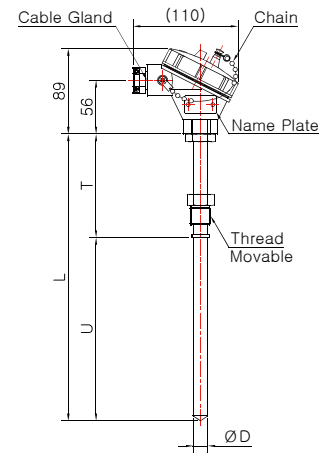

**Model No. DS-3042W-2**  
(Sheath)

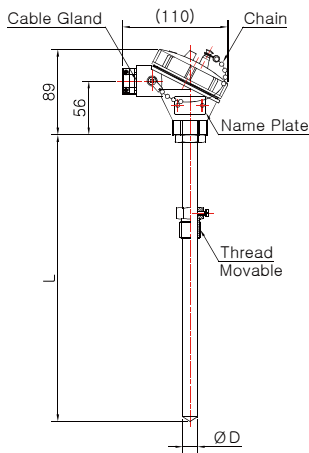

**Model No. DS-3042W-3**  
(Sheath)

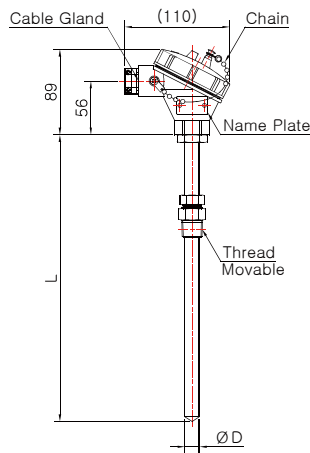

**Model No. DS-3042W-4**  
(Sheath)

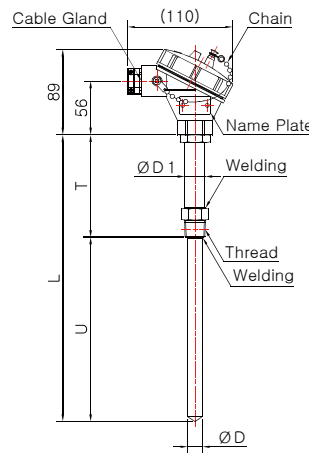

**Model No. DS-3043W**  
(Sheath)

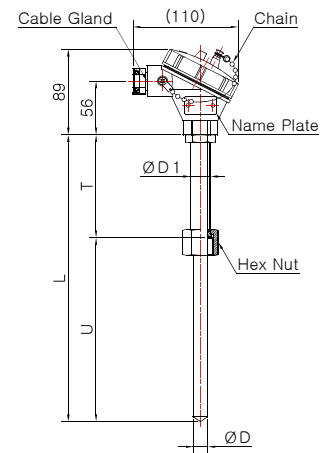

**Model No. DS-3043W-1**  
(Sheath)

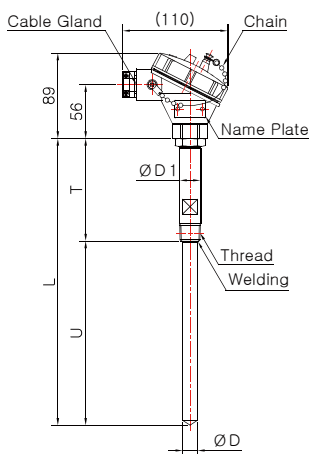

**Model No. DS-3044W-1**  
(Sheath)

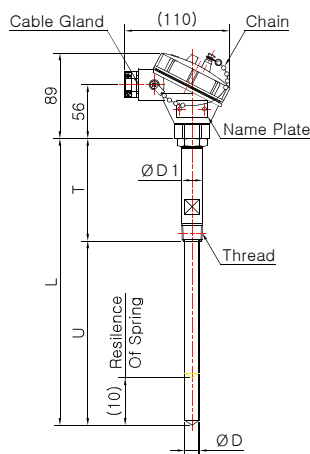

**Model No. DS-3044W-1-1**  
(Sheath Spring Load)

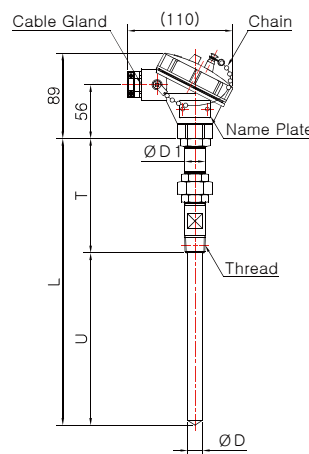

**Model No. DS-3044W-2**  
(Sheath)

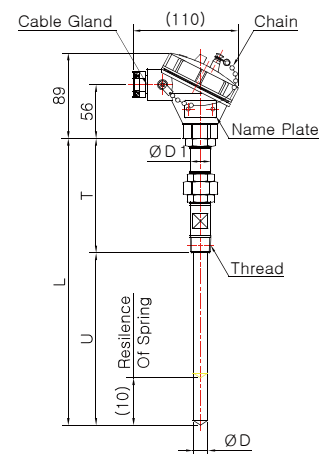

**Model No. DS-3044W-2-1**  
(Sheath Spring Load)

Pressure Gauge

Accessories

Thermometer

Thermocouple & R.T.D

Thermowell

# Resistance Temperature Detectors

## Model. DS-3040W Series

# DAESHIN

### Weather Proof Head Type

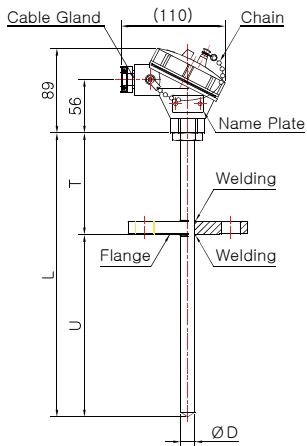

**Model No. DS-3045W**  
(Sheath)

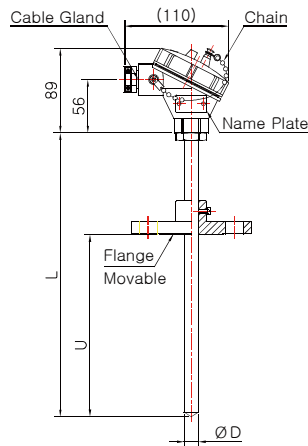

**Model No. DS-3045W-1**  
(Sheath)

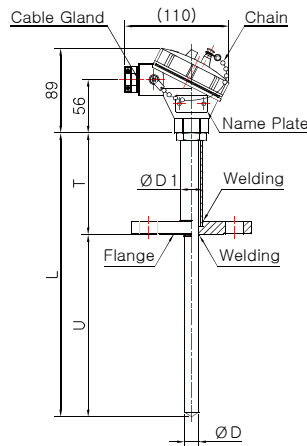

**Model No. DS-3046W-1**  
(Sheath)

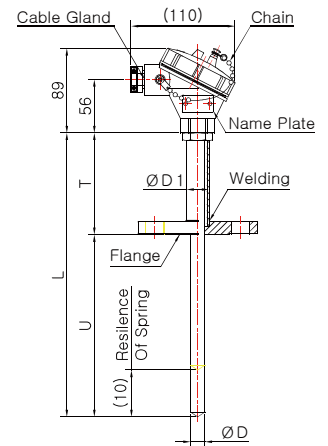

**Model No. DS-3046W-1-1**  
(Sheath Spring Load)

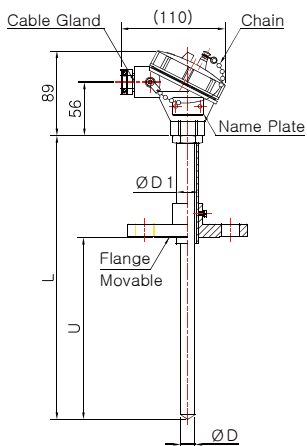

**Model No. DS-3046W-2**  
(Sheath)

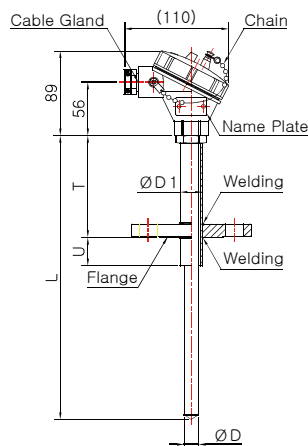

**Model No. DS-3046W-3**  
(Sheath)

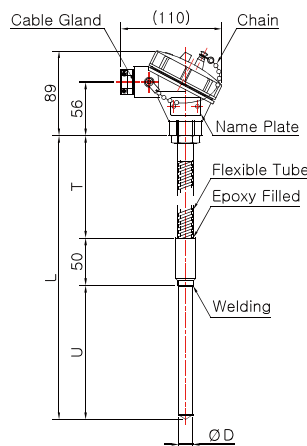

**Model No. DS-3049W**  
(Sheath)

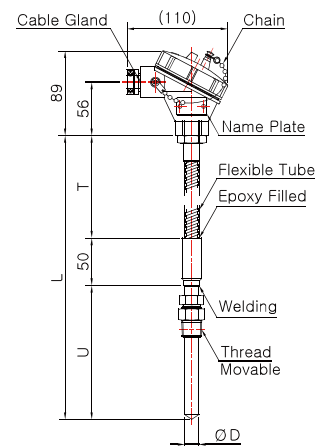

**Model No. DS-3049W-1**  
(Sheath)

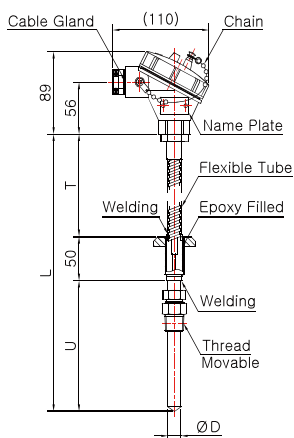

**Model No. DS-3049SW-3**  
(Sheath)

Pressure Gauge

Accessories

Thermometer

Thermocouple & R.T.D

Thermowell

# Resistance Temperature Detectors

## Model. DS-3040E Series

# DAESHIN

### Explosion Proof Head Type

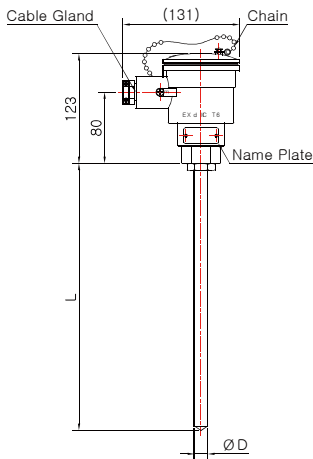

**Model No. DS-3041E**  
(Sheath)

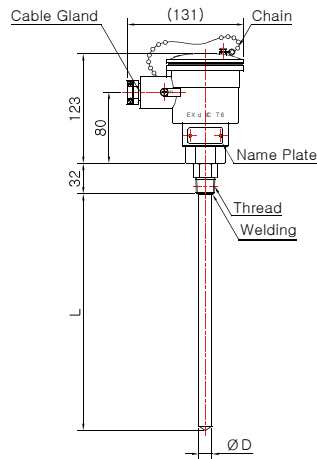

**Model No. DS-3041E-2**  
(Sheath)

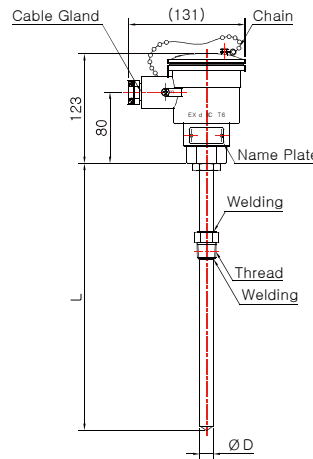

**Model No. DS-3042E-1**  
(Sheath)

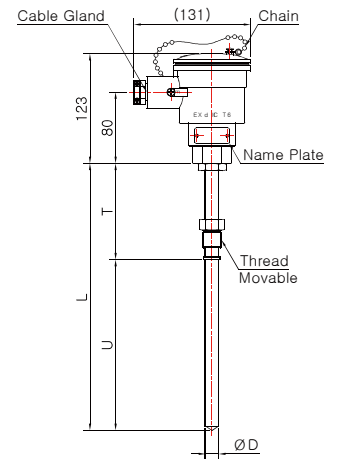

**Model No. DS-3042E-2**  
(Sheath)

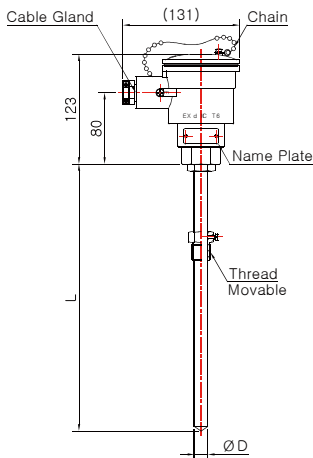

**Model No. DS-3042E-3**  
(Sheath)

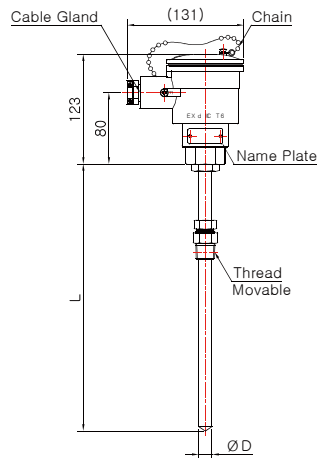

**Model No. DS-3042E-4**  
(Sheath)

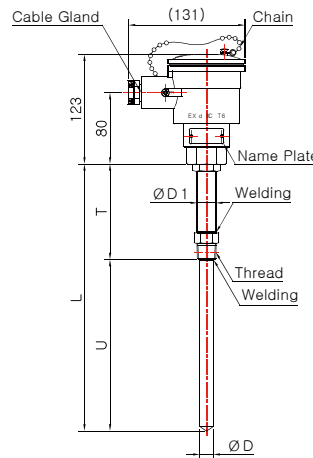

**Model No. DS-3043E**  
(Sheath)

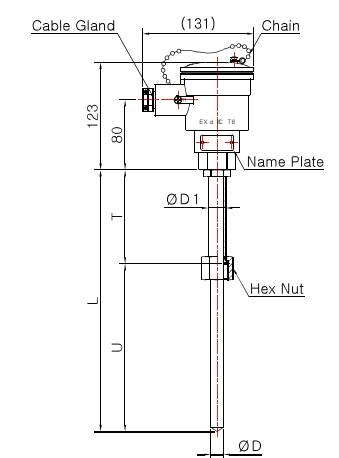

**Model No. DS-3043E-1**  
(Sheath)

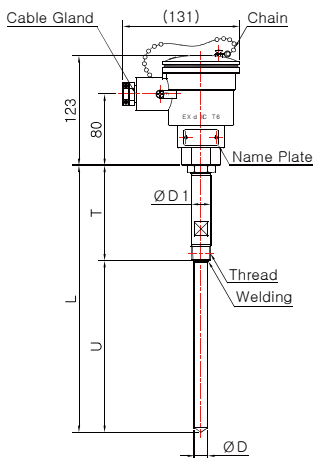

**Model No. DS-3044E-1**  
(Sheath)

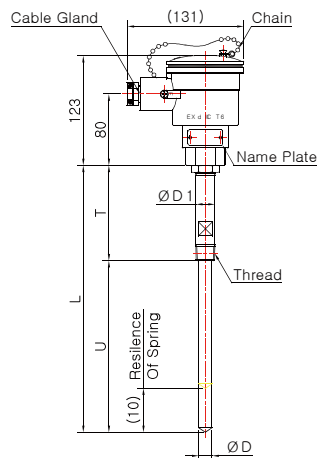

**Model No. DS-3044E-1-1**  
(Sheath Spring Load)

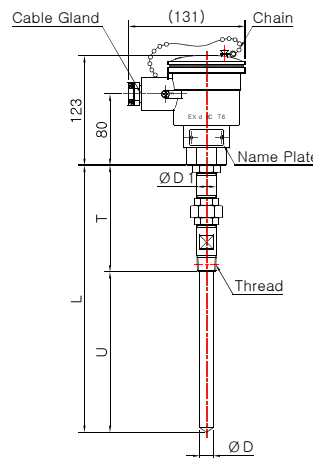

**Model No. DS-3044E-2**  
(Sheath)

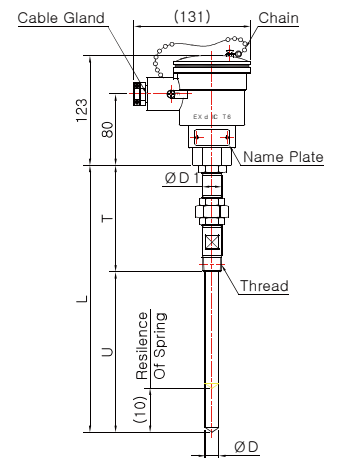

**Model No. DS-3044E-2-1**  
(Sheath Spring Load)

Pressure Gauge

Accessories

Thermometer

Thermocouple & R.T.D

Thermowell

# Resistance Temperature Detectors

Model. DS-3040E Series

# DAESHIN

## Explosion Proof Head Type

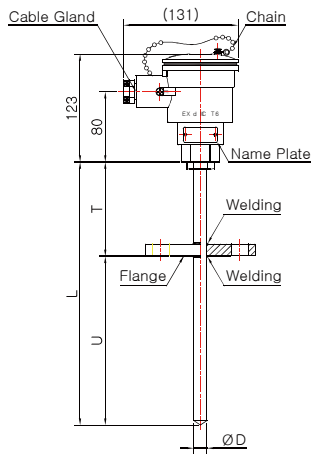

**Model No. DS-3045E**  
(Sheath)

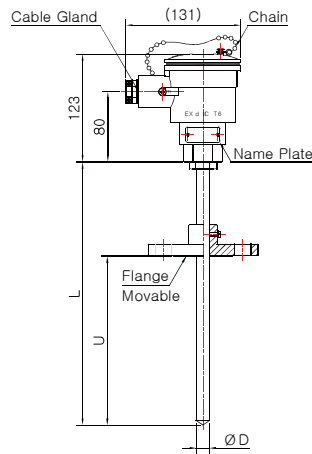

**Model No. DS-3045E-1**  
(Sheath)

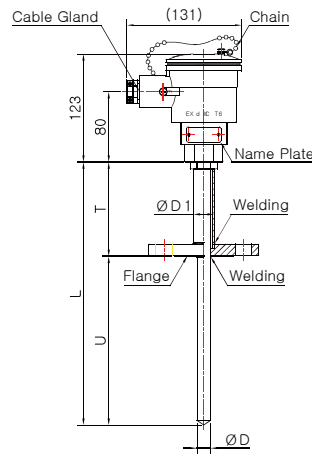

**Model No. DS-3046E-1**  
(Sheath)

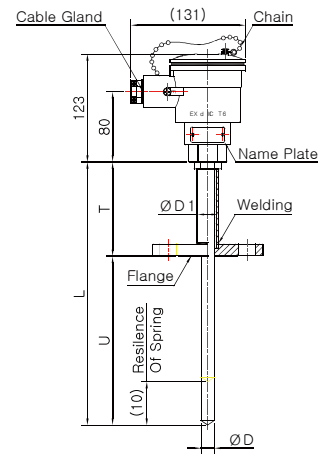

**Model No. DS-3046E-1-1**  
(Sheath Spring Load)

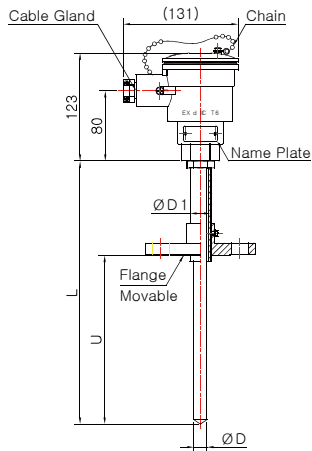

**Model No. DS-3046E-2**  
(Sheath)

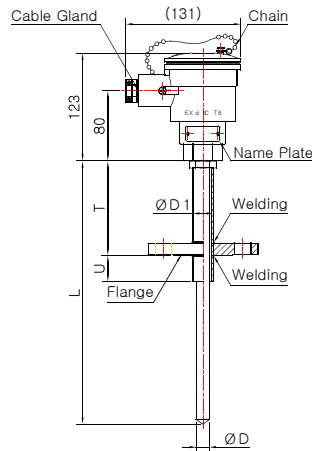

**Model No. DS-3046E-3**  
(Sheath)

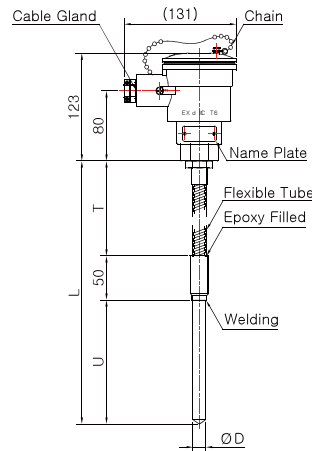

**Model No. DS-3049E**  
(Sheath)

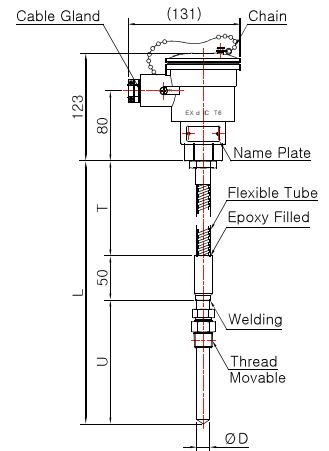

**Model No. DS-3049E-1**  
(Sheath)

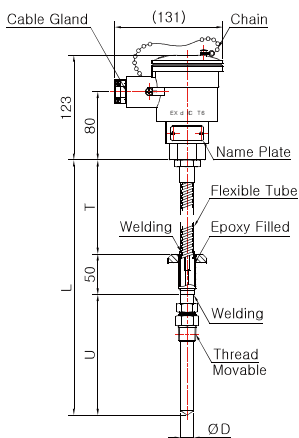

**Model No. DS-3049SE-3**  
(Sheath)

Pressure Gauge

Accessories

Thermometer

Thermocouple & R.T.D

Thermowell